

Hand Warmer Installation Instructions

For the following kit: 210007MT

ATVs (except Bombardier) and Snowmobiles (except Yamaha)

WARNING: NOT INTENDED FOR USE ON MOTORCYCLES (could melt throttle)

Caution: Heater gets hot fast. Do not energize before installation, including grip replacement, completed.

Please read instructions before installation.

INSTALLATION INSTRUCTIONS

1. Remove grips (use compressed air if available). Clean handlebar to remove any residue and dry.
2. Non throttle side hand warmer: Peel release paper from back of hand warmer and position (non throttle side) heater with wire leads at 9 o'clock position (Fig. 1). Remove air pockets by pressing with thumb and moving toward edge.
3. Throttle side hand warmer: Peel release paper from back of hand warmer and position heater with wire leads at 3 o'clock position (Fig. 1).
4. Apply a high temperature, 2-part epoxy (such as Permatex Quick Set) to area where grips will be located.
5. Install grips (use compressed air if available) and let adhesive dry.
6. Choose a location for the switch that is convenient, has sufficient rear clearance for the electrical connections, and is within 18" of a voltage-controlled wire (wire in the lighting circuit, for example).
7. Drill 1/2" (13mm) hole and install the switch from the back, keyway down. NOTE: Leave the strain relief nut on the switch.
8. On the front, install the Hi/Low indicator tab and secure the switch and tab using the metal nut. NOTE: The amount of switch barrel protruding can be adjusted by turning the strain relief nut.
9. Route wires along the handlebar and secure with supplied tie wraps, electrical tape, or both. NOTE: Cut off or bundle excess wire.
10. Attach female slip-on connectors, piggyback connectors and ring terminals as shown in Figure 2. NOTE: A crimping tool works best, or pliers will work using a double crimp approach (top crimp first and then a side crimp)
11. Connect hand warmers to switch according to Fig. 2
12. If tapping into power from an existing switch, go to step 13. If using a tap connector, skip to step 14.
13. Strip end of yellow/red wire and crimp the supplied piggyback connector to the wire. Unplug the power wire from the constant power terminal of the existing switch, attach the piggyback connector, and reinstall the slip-on connector on the male terminal of the piggyback connector. Skip to step 15.

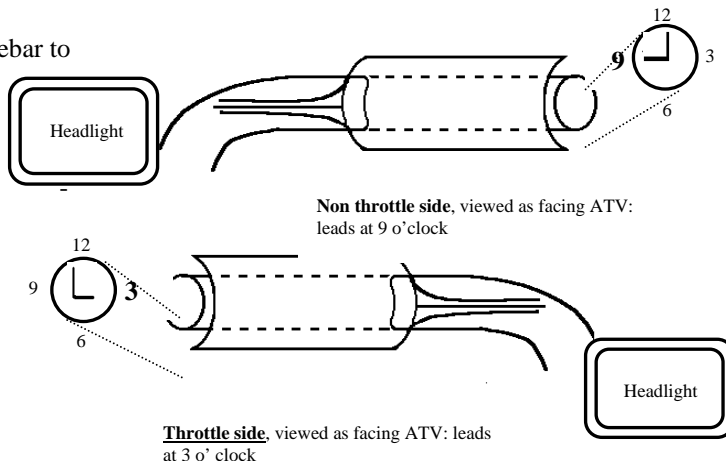

Fig. 1 Hand warmer positioning, viewed as facing ATV

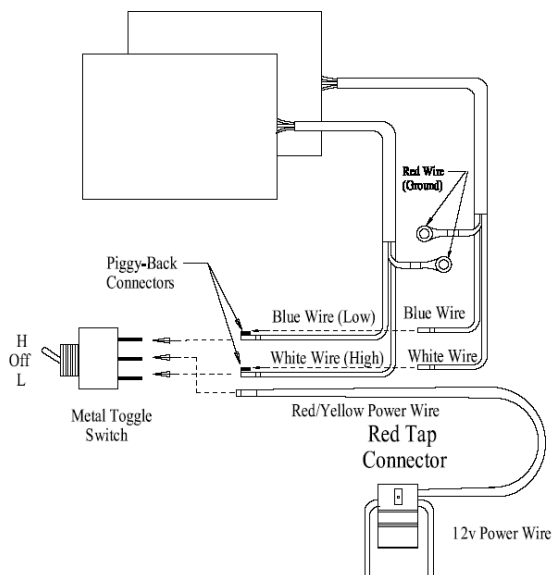

Fig. 2 Connector guide & switch connections

14. Locate a power wire leading to a headlight, taillight, or dash light. Place this power wire into the continuous channel of the red tap connector and insert the yellow/red wire (do not strip insulation) completely to stop. Using pliers, make the connection by squeezing the metal contact flush with top of connector. Close the hinged cover until latched. See Fig. 2 for connection to switch. **Note:** For protection against electrical shorts, a fuse (not included) could be installed between the tap connector and the switch. Fuse would be a 5-amp capable of handling at least 60 watts.
15. Ensure free movement of handlebar from side to side. Resistance between red wire (Ground) and white wire (High) should be 7.5 +/- 2 ohms. Resistance between red wire and blue wire (Low) should be 12.5 +/- 3 ohms.

INSTALLATION WITH THUMB WARMER (single switch)

Though a separate switch for hand and thumb warmers offers flexibility, the following describes a single switch installation (one switch controls both hand and thumb warmers simultaneously). Combining hand and thumb warmer leads into a single connector will reduce space and connector requirements.

(Figure 3) Installation with Thumb Warmer Kits 210008, 09, 12, and 13 (Polaris/Honda, for example)

- 1) Connect the Blue Wire on the thumb warmer to the Blue Wire from the hand warmer (solder or twist tie).
- 2) Connect the White Wire on the thumb warmer to the White Wire from the hand warmer (solder or twist tie).
- 3) Connect the Red wire to a good ground.

(Figure 4) Installation with Thumb Warmer Kits 210010 and 11 (Arctic Cat/Bombardier/Suzuki)

- 1) Connect black wire from thumb warmer to Low (top) terminal of the switch. (Solder or twist/crimp hand warmer (blue wire) and thumb warmer (black) wires together).
- 2) Connect the red wire from thumb warmer to the High (bottom) terminal of the switch (along with white wire from hand warmer). Connect remaining (brown) thumb warmer wire to Ground.

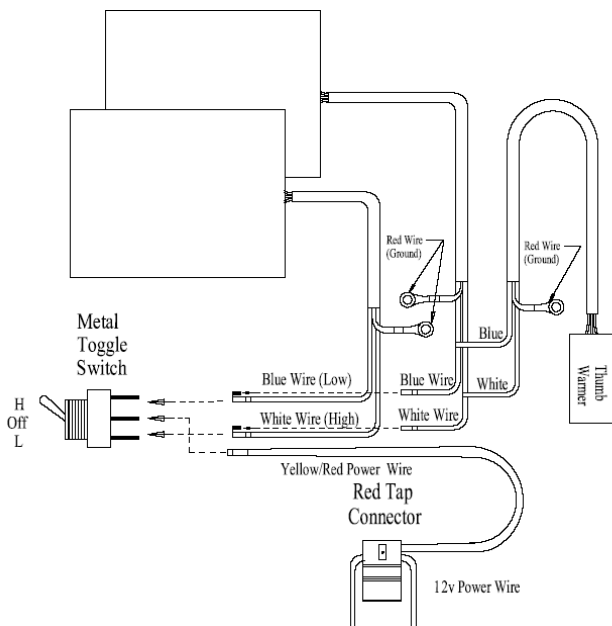

Figure 3. Hand Warmer w/210008 Type Thumb Warmer.

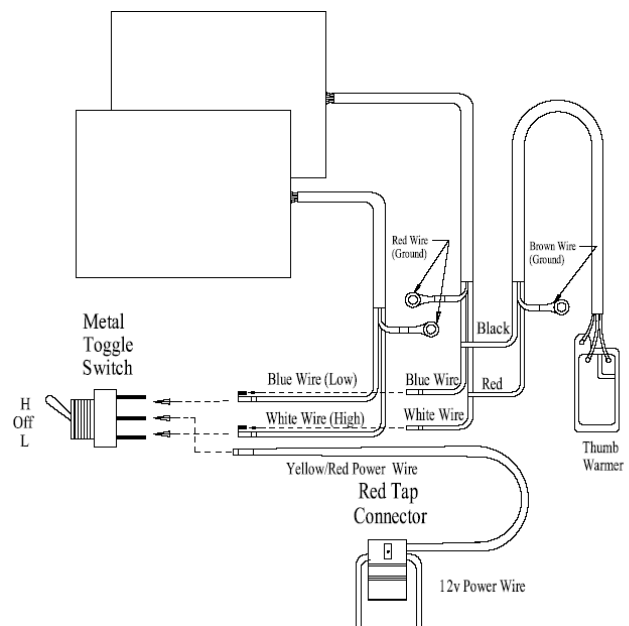

Figure 4. Hand Warmer w/210010 Type Thumb Warmer.

For technical information regarding this product, please call 763-571-9193 ext 106.