

ATV Heated Grips

For the following kits: 210024RR, 0631-0003, 0631-0017, ATV-21002-40RR, 2966

No Adhesive Required

Hi/Low Model Installation Instructions

WARNING: NOT FOR USE ON MOTORCYCLES (could deform throttle, causing it not to turn)

APPLICATION

ATVs with 7/8" bar and thumb throttle; Polaris, Honda, Arctic Cat, Yamaha, Bombardier, Kawasaki, and Suzuki

SPECIFICATIONS

Wattage: 19 watts High (38 watts total) at 13.5 volts
Resistance: Between white (Ground) and red (High) is $9.6 \pm 2 \Omega$.
Between white and blue (Low) is $19.2 \pm 3 \Omega$.

PARTS LIST



No.	Description	Qty
(1)	Heated grips	2
(2)	Round Rocker Switch	1
(3)	Power Wire	1
(4)	Piggyback connectors	2
(5)	Slip-on connectors	2
(6)	Ring connectors	2
(7)	In-line tap connector	1
(8)	Tie wraps	6

TOOLS/SUPPLIES FOR INSTALLATION

Drill with 13/16" bit	Pencil
Pliers	Crimping tool (optional)
Contact cleaner or alcohol	Electrical tape (optional)
Clean cloth	4-amp fuse (optional)
WD-40	

INSTALLATION ISSUES/INSTRUCTIONS

*****It is important that the grips be warm before installing.**

- Heater designed for operation on a handlebar in a voltage-controlled circuit; do not energize before installation or heater will be damaged
- 40 Watts or 3 Amps required (may preclude use on some older ATVs).

1. Disconnect Positive terminal from battery.

2. Remove the old grips and clean the handlebar surface of any adhesive or residue. Sand off any burrs or rough edges. Mark with a pencil or put a piece of tape 4 5/8" from the end of the handlebar. This will mark a spot so that you know when the grip is on all the way.
3. The grips push on quite hard so be prepared to apply a considerable amount of force to install them.
4. Three (3) applications of WD-40 are required. Spray the inside of the grip from the top to bottom and the outside of the handlebar with a generous amount of WD-40.
5. Wait three minutes and repeat step 4.
6. Wait 2 minutes and spray inside of grip a third time.
7. Align the grip so the cord is set at a 9:00 o'clock position and slide it onto the left end of the handlebar.

IMPORTANT: If installation is difficult, remove immediately and repeat step 5 & 6. **Assure the grip is in the correct location before the WD-40 evaporates. If grip is stuck half way and you cannot move it refer to the enclosed Installation Failure Instructions.**

8. Repeat steps 5 & 6 for the remaining grip and install on the right side with the cord at the 3:00 o'clock position.
9. Choose a location for the switch that is convenient and has sufficient rear clearance for electrical connections. Switch should be within 18" of a voltage-controlled wire (wire in the lighting circuit).

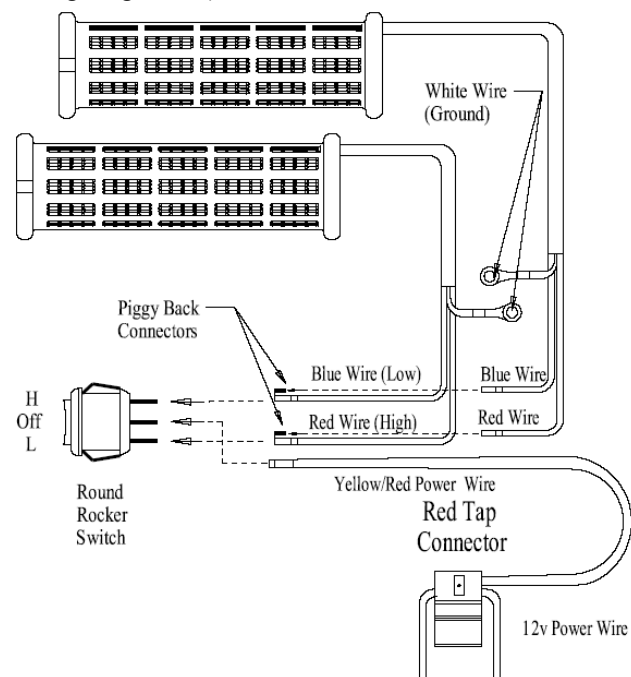

Figure 1. Connector guide & switch connections

10. Drill a 13/16" hole in this location.

11. Route wires from each heated grip along handlebar and secure with supplied tie wraps, electrical tape, or both. Route wire through hole in step #10 from the back side.
12. Attach female slip-on connectors, piggyback connectors and ring terminals as shown in Figure 1. A crimping tool works best or pliers will work using a double crimp approach (top crimp first and then a side crimp). For Ground connection (white wires) use a frame component or a Ground wire, not a rubber isolated component such as a handlebar or steering assembly.
13. Connect heated grip wired to the switch according to Figure 1, align the switch as you want to read it and insert it into hole drilled in step #10.
14. Locate a voltage controlled power wire (such as one leading to a headlight, taillight, or aux power outlet). Using the red tap connector, place this power wire into the continuous channel. Insert the yellow or red wire (do not strip insulation) into the adjacent channel. Using pliers, press the metal contact flush with top of connector. Close the hinged cover until latched. See **Figure 1** for connection to switch. **Note:** For added protection, install a 4- or 5-amp fuse (not included) between the tap connector and the switch.
15. Reconnect positive battery terminal. Confirm no battery drain when ignition key is in the Off position.

INSTALLATION WITH THUMB WARMER

(Single switch)

Though a separate switch for hand and thumb warmers offers flexibility, the following describes a single switch installation (one switch controls both hand and thumb warmers simultaneously). Combining hand and thumb warmer leads into a single connector will reduce space and connector requirements.

Warning: Ensure free movement of throttle and handlebar from side to side (and any other control in handlebar area).

Caution: Older ATVs may not provide sufficient wattage to operate headlight and heated grips at the same time without dimming the headlight. Turn heated grips Off during low light conditions if visibility is poor/limited.

(Figure 2) Installation with Thumb Warmer Kits 210008, 09, 12, and 13 (Polaris/Honda, for example)

1. Connect the Blue Wire on the thumb warmer to the Blue Wire from the hand warmer (solder or twist tie).
2. Connect the White Wire on the thumb warmer to the Red Wire on the hand warmer (solder or twist tie).
3. Connect the white wire on the hand warmer and the red wire on the thumb warmer to a good ground.

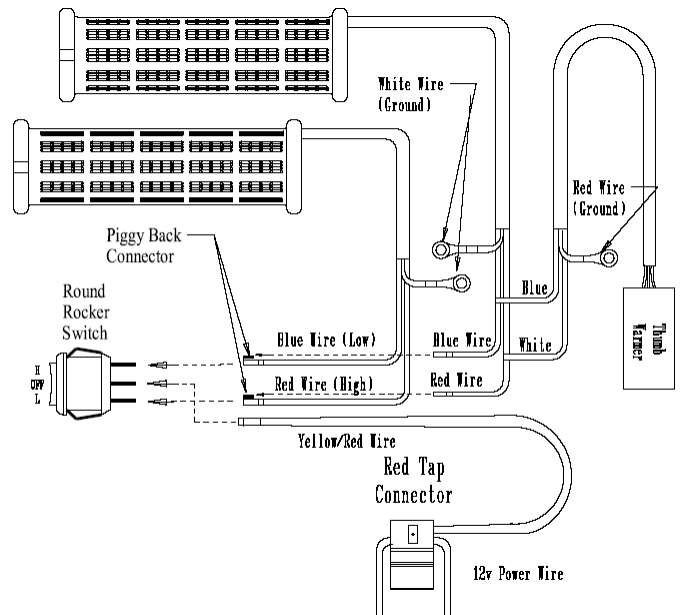

Figure 2. Hand Warmer w/210008 Type Thumb Warmer

(Figure 3) Installation with Thumb Warmer Kits 210010 and 11 (Arctic Cat/Bombardier/Suzuki)

1. Connect Black Wire from thumb warmer to the Blue Wire from the hand warmer (solder or twist tie).
2. Connect the Red Wire from the thumb warmer to the Red Wire on the hand warmer (solder or twist tie).
3. Connect remaining Brown Wire on the thumb warmer and the white wires on the hand warmer to a good ground.

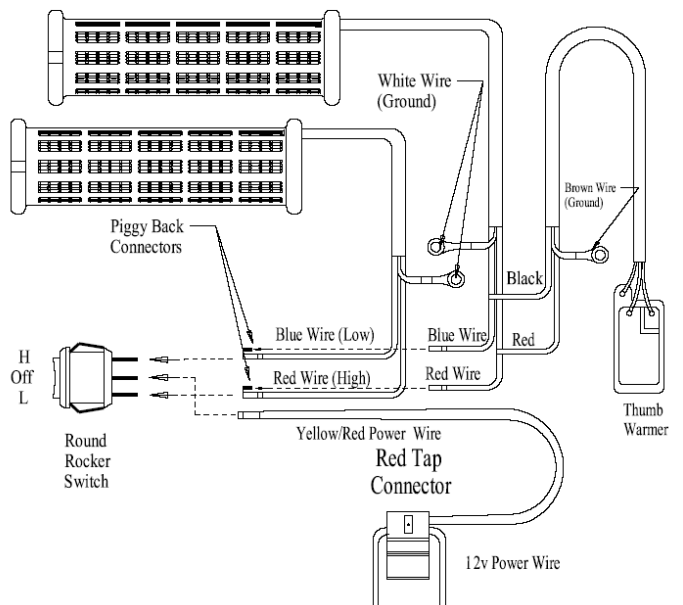

Figure 3. Hand Warmer w/210010 Type Thumb Warmer

For technical information regarding this product, please call 763-571-9193 ext 106.