



HEAT DEMONS INSTALLATION INSTRUCTIONS



This kit is designed to fit all Harley-Davidson motorcycles except the 2008 and later Touring models with Electronic Throttle and the models that have inserts inside the handlebar.

!!Warning!! A Service Manual is required to install this kit. The rider's safety depends upon the correct installation of this kit. If the procedure is not within your capabilities or you do not have the correct tools, have your Harley-Davidson dealer perform the installation. Improper installation of this kit could result in death or serious injury.

Components: This 'HEAT DEMONS' Grip Warmers Kit includes the internal heaters for the handlebar, the 4 level temperature controller, epoxy adhesive, electrical wires and silicone grease filled connectors, rubber grommet, plastic stir sticks, craft stick, wire ties, and a plastic snake to assist the installation.

Tools: A 3/8" Drill, 5 sharp drill bits from 3/32" to 5/16" or a step drill, a hammer and center punch, a round file, a pliers and wire cutter, a small straight blade screw driver, T25 and T27 TORX drives, and safety glasses.

Installation: These instructions describe installing the Heat Demons with the temperature controller mounted on the LEFT side. To install with the controller mounted on the RIGHT side, follow these instructions except where it references LEFT and CLUTCH or RIGHT and THROTTLE exchange these and also exchange the mounting of the controller from the CLUTCH SIDE to the THROTTLE SIDE.

WARRANTY AND DAMAGE: This product has a 1 (one) year Limited Warranty. The warranty does not cover misuse of this product or operation outside of the design specifications. Symtec, Inc. WILL NOT be responsible for damages made to products that are not installed properly. Symtec, Inc. products have recommended installation instructions that are written to provide proper guidelines for product installations. Warranties WILL NOT be honored on broken items or damaged electronics due to shorting or pinched wires.

A. Open or remove the seat according to the service-manual instructions.

!!! Warning !!! Warning

To protect against shock and accidental start-up of the vehicle, disconnect the battery cables, negative cable first, before proceeding. Inadequate safety precautions could result in death or serious injury.

!!! Warning !!! Warning

Always disconnect the negative battery cable first. If the positive battery cable should contact ground with the negative cable installed, the resulting sparks may cause a battery explosion that could result in death or serious injury.

B. Disconnect the battery, negative cable first, according to the service-manual instructions.

There are two options for installing the Heat Demons. Option A is doing the installation without removing the handlebar and Option B includes the removal of the handlebar. A hole or holes need to be drilled in the handlebar and the Option chosen depends on how comfortable the installer is on drilling a hole in the bottom of the bar. One advantage for removing the handlebar is the Right Handlebar Control and Grip can be left intact during the installation. The disadvantage is on some models the headlight and trim pieces need to also be removed.

Option A – Installation without removing the handlebar.

1. Remove the Right Handlebar Control, upper and lower switch housing screws, and Right Grip from the Handlebar according to the service-manual instructions and set aside or leave hanging. Remember to insert a spacer between the rear brake light switch and the lever to keep the switch from being broken.
2. Remove the Left Hand switch housing from the handlebar according to the service-manual instructions.
3. Using a T27 TORX drive head remove the half of the clamp that secures the clutch hand lever to the handlebar and discard. The Heat Demon controller will replace this clamp when finishing the installation. Separate the clutch hand lever assembly from the handlebar and move away from the bar.
4. Mark the location of the Left Grip and remove it by twisting, heating, injecting brake cleaner fluid or with air pressure. Almost all grips can be removed without damage. If this does not work it may be necessary to cut the grip for removal.
5. A hole needs to be drilled in the bottom of the handlebar to route the power wires and wires from the Controller. The location of the hole should be in the groove or recess on the bottom of the handlebar under the Left Switch Housing at the end of the groove toward the grip. Start by punching a hole location with a center punch to pierce the chrome. **Use safety glasses that completely cover the eyes to protect from steel chips while drilling!** Start with a small drill like a 3/32" size to make the initial hole. Then use progressively larger drills or a step drill to increase the hole size to 5/16". After the hole is drilled use a round file or deburring tool to remove the sharp edges.

6. **Pulling the wires through the handlebar.** Uncoil the plastic snake from the kit, clip (taper) off squared corners of the feed line on the opposite end of the drilled hole and run it from the right end of the handlebar out the left end. Twisting the snake or inserting it vertically versus flat can help to push around the corners.
7. **Attach the white and yellow wires from the Right Grip Heater (Item 3) to the hole in the plastic snake** and pull them through the bar so they exit the left end. (See drawing below) *For ape type high rise handlebars, additional lengths of wire need to be soldered to these wires. Shrink tube over the soldered areas is necessary.
8. **Push the right heater into the handlebar by squeezing it together and sliding it fully inside of the bar.** The end of the heater with the orange or black cap should be pushed in first. Cut the white and yellow wire to extend 4 inches beyond the left end of handlebar.
9. With a small screwdriver, **install the small rubber grommet into the hole that was drilled in the handlebar.** The hole will not be round so the grommet needs to be worked into position. Be careful not to push the grommet into the inside of the bar.
10. Next **push the 4 wires from the Controller through the hole in the grommet so they extend out the left end of the handlebar.** It works best to push them one at a time. Let the Controller hang down 1" from the handlebar.
11. **The Red and Black non-stripped wires from the end of the jacketed power cable also need to be pushed through the hole** in the grommet so they extend 4" out the left end of the handlebar. Let the rest of the cable hang.
12. **The wire connections are done near the left end of the handlebar.** Hold the Left Grip Heater (Item 2) near the end of the bar so these wires can be connected to the other wires that extend out the end of the bar. **Use the small connectors, from the parts bag, with 2 holes to connect the two green and then the two red wires.** Push the wires into the holes so they extend as far as possible into the connector. The wires can be viewed from one side of the clear plastic. With the wires pushed to the end take pliers and push the yellow cap down completely flat (**see example below**). This will pierce the wires and make the connection and some moisture resistant grease will be pushed out of the connector. **The cap needs to be pushed down completely so the grease comes out of the connector otherwise it will not make the electrical connection.** Wipe off the grease and pull on the wires to make sure they are connected. If they are not connected there is one extra connector, or the wires will need to be stripped and soldered.

VERY IMPORTANT
CONNECTORS MUST BE FULLY CRIMPED



13. **Next use the connectors with 3 small holes to connect the 3 white, 3 yellow, and 3 black wires.** Push the wires into the connectors to the end and using pliers push the red cap down to pierce the wires and make the connection like shown above. Grease will also need to be pushed out to assure a good connection. Wipe off the grease and pull on the wires to assure a good connection. If the wires are soldered assure that sufficient heat is applied to melt the solder and that it flows around the wires so a cold solder joint does not result. The following wiring diagram shows the connections.

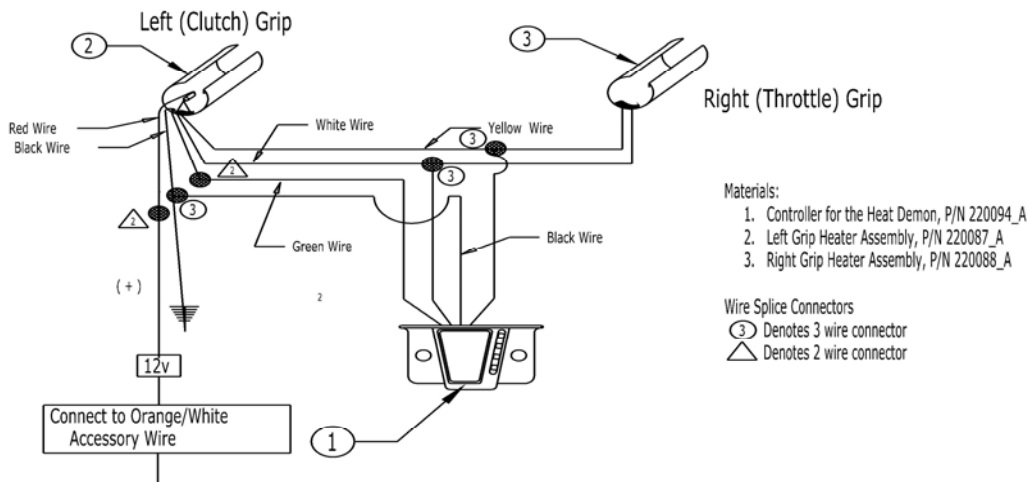

14. **Fold the wires and connectors inside of the Left Grip Heater** and push into the left end of the handlebar by squeezing together and sliding it along with the wires until completely inside. The end of the heater with the orange or black cap should be pushed in first and the power cable can be pulled out as the heater is pushed in, so the wires are not cut.

15. **Product test before finalizing the installation of the Heater, Controller, and Left and Right Side components.** Connect the Red and Black wires of the power cable to 12V temporarily to confirm the proper operation. Press the button on the Controller multiple times and confirm the 4 LED's light from yellow to red and off. Next press the button so all 4 LED's are on. Leave the power on for 5 minutes or more to confirm good wire connections and that the heaters are working properly. Each end of the handlebar should get to 160° F without the grip and should be so hot it is not possible to keep touching.

Finishing up the install

16. **Install the Right Throttle Control and Grip** according to the service manual.
17. **The Left Grip should be installed on the handlebar at the previously marked position followed by the Switch Housing.** (Instructions for installing the Left Grip are detailed on the last page). Be sure the ribs on the outboard side of the switch housing fit in the grooves molded into the grip.
18. **Verify that the wire harness conduit runs in the groove at the bottom of the handlebar.** Be sure that the upper switch housing harness will not be pinched under the handlebar when the switch housing screws are tightened.
19. **Attach the Controller to the clutch hand lever assembly by first starting the screws but do not tighten.** Assure the wires from the Controller and the power wires fit into the opening on the front side of the Switch Housing with the wire harness conduit and are not pinched when the Controller is tightened to the clamp.
20. **Note!! Tighten the screws that hold the Controller to the clutch hand lever assembly, but do not over tighten because it can damage the Controller. Tighten the screws to 50 in-lbs. It is important to tighten the screws equally on each side so the gap is the same between the Housing and the lever assembly. When tight there will be a small gap of about 1/32" on each side. If you do not have a torque wrench, hand tighten with a T27 or T25 TORX screwdriver handle that is equivalent to about 30 in-lbs. Then use a small 1/4" socket drive handle and tighten the screws another 1/4 turn. This will result in a holding force of 40 to 50 in-lbs of torque. Press on the clutch hand lever assembly to assure it does not move.**
21. Run the power cable along the wire harness conduit under the gas tank to the battery area. Add wire ties where needed. The plastic snake can be used to bring the cable through the panels and under the gas tank without removing it.
22. **The power wires should be connected to the Accessories circuit.** The Heat Demons draw 3 amps so a check should be made to assure the circuit is not overloaded. Connect the Red wire to the Orange wire with a white stripe near the battery or behind the head light with the red splice connector, from the parts bag. On older bikes it can be the white wire. Connect the Black wire to a good ground location with the ring terminal or to another black wire with the red splice connector. On 2011 Softtail models the power wires should be run under the seat and attached to a Matrix connector near the battery. The mating Matrix connector part number is 72673.
23. Reconnect the battery cables. **!!Warning!! Always connect the positive battery cable first.**
24. Turn on the accessories switch and check that the Controller is wired properly by pressing the button and confirm that each time it is pressed the 4 lights turn on sequentially and turn off the fifth time it is pressed.

Option B – Installation removing the handlebar.

1. Loosen the screws on the Right Hand Control and Switch housing so the handlebar can slide out leaving the assembly and Right Grip in position.
2. Remove the handlebar.
3. Follow steps 2 thru 19 above. An additional 5/16" hole can be drilled in the bottom center of the handlebar if it is desirable to run the power wires inside of the bar.
4. Reinstall the handlebar and tighten the screws on the Right Side Control.
5. Complete the installation following steps 20 to 24 above.

Operation:

The Controller will provide 4 levels of heat to the heaters inside of the handlebar. A thermistor senses the temperature and provides a feedback to the Controller so a precise level of heat is supplied to the grips.

Press the button on the Controller once and the Yellow light or LED shows that the lowest level of heat is selected.

Press the button a second time and the Orange light or LED will indicate the next higher level of heat has been selected.

Pressing the button a third time the Red/Orange LED is on and the fourth time the deep Red LED is on indicating the highest level of heat have been selected for colder conditions.

Pressing the button a fifth time will shut off all of the lights and the power.

Holding the button down for 3 seconds will lower the intensity of the LED's for night operation. Holding it down again for 3 seconds will adjust the LED's for daytime use.

Left grip installation Instructions:

As the grips are heated the rubber or polymer material becomes more flexible and this makes the adhesion to the handlebar more difficult. Likewise, new grips have a slippery mold release material on the inside of the grip and this also makes it more difficult to adhere the grips. The following installation steps need to be followed to assure the grips will be secured to the handlebar.

The following instructions describe the application of a two part epoxy adhesive and the installation of the Left Grip. The various rubber or polymer grip designs are typically the standard molded one piece or the metal and resilient material assembly like the ISO version from Kuryakyn. The installation is different so each is described below.

A. Standard One Piece Grip

The one piece grip is typically smooth on the inside and will squeegee off the epoxy adhesive that is applied when it is pushed onto the handlebar. Utilizing the plastic stir sticks that are included in the kit will help to keep the adhesive under the grip and secure it to the bar.

1. We recommend roughening the inside of the grip to remove the mold release oil or old adhesive and provide grooves that the adhesive can attach to. Use a piece of coarse sandpaper to abrade the inside of the grip.
2. Cut the end off the epoxy adhesive pack and squeegee out both materials. Mix the two parts very well with the enclosed craft stick.
3. Place 1/3 of the epoxy adhesive around the bottom inside of the grip. Place another 1/3 of the adhesive in a line inside of the grip from the bottom to the entrance of the grip. Spread the remaining epoxy adhesive around the inside entrance of the grip.
4. Holding the grip horizontal with the adhesive line on the bottom, place the two plastic stir sticks inside of the grip 1/4" to 1/2" apart on each side of the adhesive line placed in Step #3.
5. Hold the ends of the plastic stir sticks so they extend about 1" outside of the end of the grip and rotate it so the stir sticks are on top. Slide the grips onto the handlebar trapping the stir sticks between the grip and the handlebar. Push the grip onto the bar to the point marked previously.
6. Remove the plastic stir sticks by bending up the ends and pulling out with a pliers. This will allow the adhesive to spread out inside of the grip. If one of the stir sticks should break, cut it off and leave inside of the grip. Wipe off any excess adhesive.
7. The epoxy adhesive will cure in 18 hours at room temperature or it will cure in 2 hours with the Heat Demon Controller set to the highest heat level. Do not move the grips until the epoxy adhesive is cured.

B. Kuryakyn Style Grips

The following steps describe the installation procedure for this metal and polymer style grip that typically has many cavities on the inside.

1. Complete step #1 and #2 from above. It is important to thoroughly roughen the inside of the grip.
2. Follow step #3 above but skip parts #4, #5, and #6 because the stir sticks are not used. When all of the adhesive is inside the Left Grip slide it onto the handlebar to the point previously marked for its location. Rotate the grip to the desired orientation and wipe off any excess epoxy adhesive.
3. The epoxy adhesive will cure in 18 hours at room temperature or it will cure in 2 hours with the Heat Demon Controller set to the highest heat level. Do not move the grips until the epoxy adhesive is cured.

Trouble Shooting Tips:

The majority of problems encountered with the Heat Demons installation and operation are related to the electrical connections. The problem with the grips not heating or the grips not getting hot enough are usually related to poor wire connections.

1. Check the plastic connectors to assure the wires are pushed all the way in and the caps are pushed completely flat.
2. Solder the wires if there is a question with the plastic connectors. Solder correctly so the heat applied will cause the solder to flow completely into the wires and not just on the surface which can result in a cold solder joint.
3. Check to assure there is a good ground connection which is very important. If necessary go directly to the ground or negative terminal on the battery.

B. Additional system operation checks for components.

1. If the LED's do not light on the Controller disconnect all of the wires going to the Controller and only connect the white wire to 12V positive from the battery and the Black wire to the ground or negative on the battery. Press the button to confirm the LED's light which indicates the Controller is OK. If the LED's do not light the electronics have been destroyed and the green wire should be checked for a direct connection to ground and repaired before the Controller is replaced.
2. If one grip gets hot and the other is cold check the white and yellow wire connections going to the heater on that side.
3. If both heaters are on all the time and get too hot no matter what setting the Controller is on or even if it is off, then one of the yellow wires is making contact with ground somewhere through a pinched or cut wire insulation.
4. If one LED blinks when power is applied then goes off there is probably a poor ground or the 12V supply is on the control side of a relay versus the power side.
5. If the LED's are dim and it is not possible to change heat levels the button is binding or stuck down. The two screws on the bottom of the Controller can be removed and the button and electronics can be pushed out so the button can be adjusted.



6227 University Avenue NE Minneapolis, MN 55432
(763) 571-9193
www.heatdemons.com email: sales@symtec-inc.com